

DESCRIPTION

The ST-312B is a two-step telescopic floor microphone stand with foldable legs.

SPECIFICATIONS

Enlarged Extensible Length	910 - 1633 mm (35.83" - 64.29")
Mounting Screw	W3/8 (pipe thread), U5/16 (adapter)
Finish	Steel pipe for general use, black, semi-gloss paint
Weight	2.6 kg (5.73 lb)
Accessory	Thread adapter *1

APPEARANCE

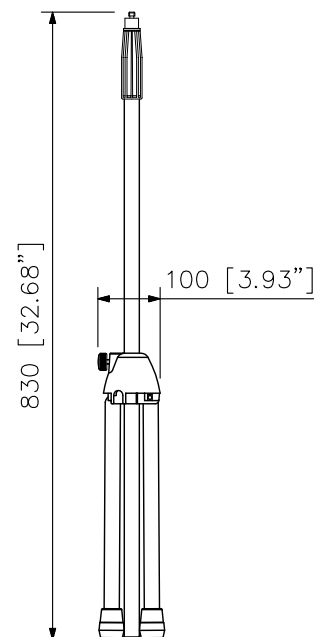
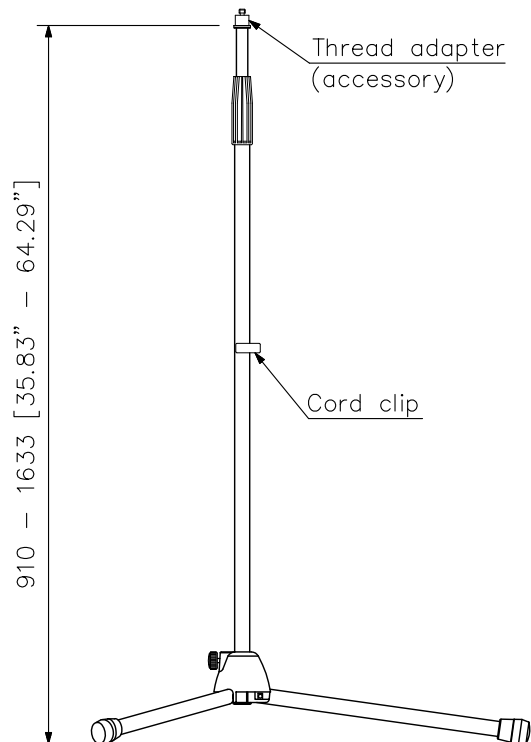
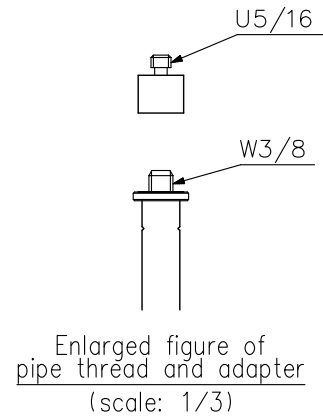
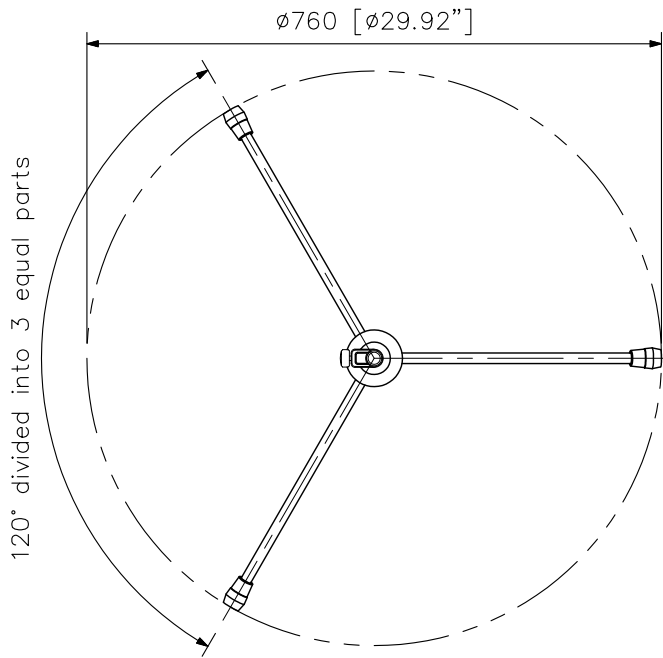

UNIT:mm SCALE:1/10